



XHRL Series

XHRL 12360W Datasheet

12V Top Terminal VRLA-AGM



Valve Regulated Lead Acid (VRLA) Battery

Maintenance-Free, Absorbent Glass Mat (AGM) Technology for Efficient Gas Recombination of up to 99%

Pure Lead Construction and Proprietary Elements

Designed for High-Rate UPS, Float Service Standby Power Applications

Built in Accordance with IEC 60896-21/22:2004 and UL1989 Recognized (MH14533)



Specifications

Voltage (Vdc)	12
Nominal Capacity (1.67 VPC @25°C)	360W @15min-rate
Watts Per Cell (30-Sec 1.67 VPC @ 25°C)	--
Watts Per Cell (5-Min 1.67 VPC @ 25°)	667.17
Watts Per Cell (15-Min 1.67 VPC @ 25°)	372.67
Max Charge Current (A)	36.00
Max Discharge Current (A)	800
Short Circuit Current (A)	2551
Internal Resistance (mΩ)	Approx. 3.10
Terminal Type	12 thread lead alloy terminal to accept M6 bolt
Terminal Torque	51.7±10.3 Kgf·cm / 44.9±9.0 Lbf·in / 5.1±1.0 N·m
Container Material	PP (UL 94-HB) & Flame Retardant (94-V0) available upon request
Weight (kg. / lb., Approx.)	28.30 / 62.37
Length (L) (mm / in)	261.0±2.5 / 10.28±0.10
Width (W) (mm / in)	168.5±2.0 / 6.63±0.08
Height (H) (mm / in)	213.5±2.5 / 8.41±0.10
Design Life	Up to 10 Years in Standby Service at 25°C Eurobat (20°C): >12 Years Very Long Life
Operating Temperature	Nominal: 25°C (77°F) Discharge: -15°C - 50°C (5°F-122°F) Charge/Storage: -15°C - 40°C (5°F - 104°F)
Float Charging Voltage	13.5 - 13.8 Vdc/battery 25°C (77°F)
Eq. Charging Voltage	14.4 - 15.0 Vdc/battery 25°C (77°F)
Self-Discharge	Less than 10% after 90 days, can be stored up to 6 months at 25°C (77°F); Fully recharging is required before usage, and charged sooner if stored at higher temperature than 25°C (77°F).



XHRL Series

XHRL 12360W Datasheet

12V Top Terminal VRLA-AGM

Constant Current Discharge Characteristics Unit: A (25°C, 77°F)

F.V/Time	2MIN	4MIN	5MIN	6MIN	8MIN	10MIN	15MIN	20MIN	30MIN	45MIN	60MIN	90MIN
10.02V (1.67 VPC)	524	421	386	360	308	272	200	159	116	82.8	65.2	46.6
10.50V (1.75 VPC)	438	364	334	310	275	240	185	150	111	80.3	63.7	45.9
10.80V (1.80 VPC)	366	316	295	278	243	215	170	140	106	77.1	61.5	44.7

Constant Power Discharge Characteristics Unit: W (25°C, 77°F)

F.V/Time	2MIN	4MIN	5MIN	6MIN	8MIN	10MIN	15MIN	20MIN	30MIN	45MIN	60MIN	90MIN
10.02V (1.67 VPC)	5399	4381	4003	3701	3270	2864	2236	1799	1324	957	760	550
10.50V (1.75 VPC)	4586	3834	3562	3355	2943	2617	2097	1708	1280	933	746	544
10.80V (1.80 VPC)	4067	3454	3277	3047	2671	2411	1936	1601	1225	900	723	531

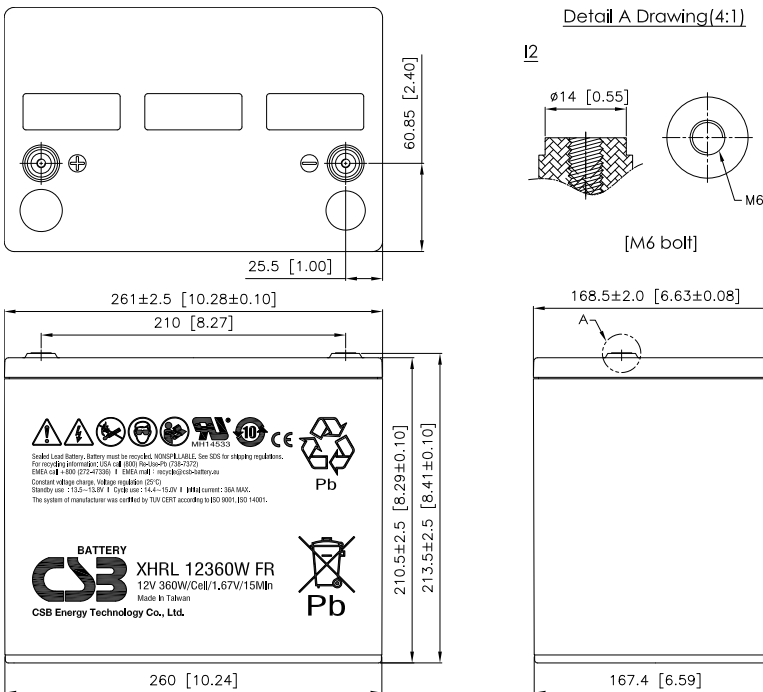



XHRL Series

XHRL 12410W Datasheet

12V Top Terminal VRLA-AGM



Valve Regulated Lead Acid (VRLA) Battery

Maintenance-Free, Absorbent Glass Mat (AGM) Technology for Efficient Gas Recombination of up to 99%

Pure Lead Construction and Proprietary Elements

Designed for High-Rate UPS, Float Service Standby Power Applications

Built in Accordance with IEC 60896-21/22:2004 and UL1989 Recognized (MH14533)



Specifications

Voltage (Vdc)	12
Nominal Capacity (1.67 VPC @25°C)	410W @15min-rate
Watts Per Cell (30-Sec 1.67 VPC @ 25°C)	--
Watts Per Cell (5-Min 1.67 VPC @ 25°)	729.83
Watts Per Cell (15-Min 1.67 VPC @ 25°)	417.33
Max Charge Current (A)	41.00
Max Discharge Current (A)	800
Short Circuit Current (A)	3171
Internal Resistance (mΩ)	Approx. 2.90
Terminal Type	12 thread lead alloy terminal to accept M6 bolt
Terminal Torque	51.7±10.3 Kgf·cm / 44.9±9.0 Lbf·in / 5.1±1.0 N·m
Container Material	PP (UL 94-HB) & Flame Retardant (94-V0) available upon request
Weight (kg. / lb., Approx.)	32.60 / 71.85
Length (L) (mm / in)	308.7±2.5 / 12.15±0.10
Width (W) (mm / in)	169.0±2.0 / 6.65±0.08
Height (H) (mm / in)	213.6±2.5 / 8.41±0.10
Design Life	Up to 10 Years in Standby Service at 25°C Eurobat (20°C): >12 Years Very Long Life
Operating Temperature	Nominal: 25°C (77°F) Discharge: -15°C - 50°C (5°F-122°F) Charge/Storage: -15°C - 40°C (5°F - 104°F)
Float Charging Voltage	13.5 - 13.8 Vdc/battery 25°C (77°F)
Eq. Charging Voltage	14.4 - 15.0 Vdc/battery 25°C (77°F)
Self-Discharge	Less than 10% after 90 days, can be stored up to 6 months at 25°C (77°F); Fully recharging is required before usage, and charged sooner if stored at higher temperature than 25°C (77°F).



XHRL Series

XHRL 12410W Datasheet

12V Top Terminal VRLA-AGM

Constant Current Discharge Characteristics Unit: A (25°C, 77°F)

F.V/Time	2MIN	4MIN	5MIN	6MIN	8MIN	10MIN	15MIN	20MIN	30MIN	45MIN	60MIN	90MIN
10.02V (1.67 VPC)	552	463	427	399	341	302	229	183	133	95.7	75.6	54.2
10.50V (1.75 VPC)	469	402	370	343	304	269	212	171	128	92.5	73.6	53.3
10.80V (1.80 VPC)	402	349	326	309	272	242	195	160	121	88.3	70.8	51.9

Constant Power Discharge Characteristics Unit: W (25°C, 77°F)

F.V/Time	2MIN	4MIN	5MIN	6MIN	8MIN	10MIN	15MIN	20MIN	30MIN	45MIN	60MIN	90MIN
10.02V (1.67 VPC)	5600	4794	4379	4058	3599	3166	2504	2068	1580	1124	883	628
10.50V (1.75 VPC)	4887	4179	3899	3684	3242	2901	2362	1972	1529	1095	865	620
10.80V (1.80 VPC)	4307	3763	3603	3348	2958	2687	2207	1863	1468	1058	839	605

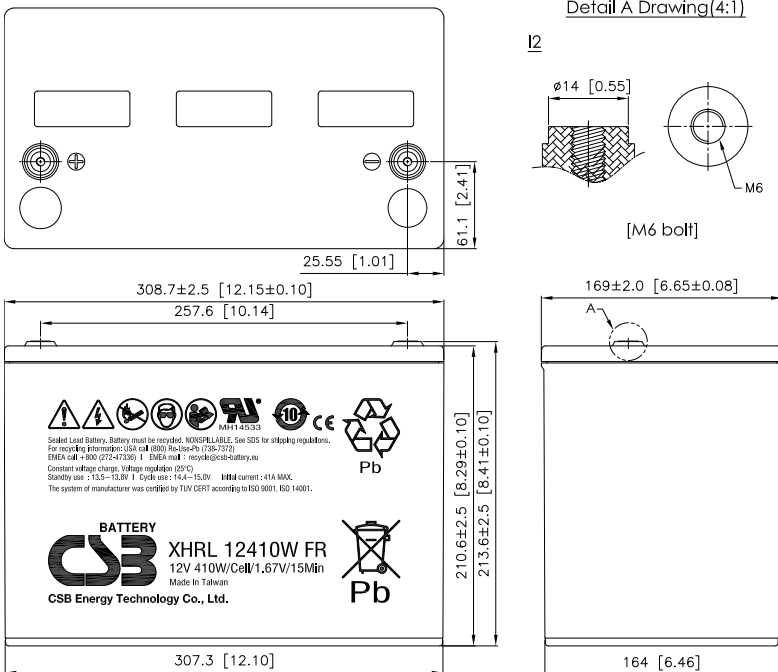



XHRL Series

XHRL 12500W Datasheet

12V Top Terminal VRLA-AGM

Specifications

Voltage (Vdc)	12
Nominal Capacity (1.67 VPC @25°C)	500W @15min-rate
Watts Per Cell (30-Sec 1.67 VPC @ 25°C)	--
Watts Per Cell (5-Min 1.67 VPC @ 25°)	912.17
Watts Per Cell (15-Min 1.67 VPC @ 25°)	502.83
Max Charge Current (A)	50.00
Max Discharge Current (A)	1200
Short Circuit Current (A)	3685
Internal Resistance (mΩ)	Approx. 2.22
Terminal Type	12 thread lead alloy terminal to accept M6 bolt
Terminal Torque	51.7±10.3 Kgf·cm / 44.9±9.0 Lbf·in / 5.1±1.0 N·m
Container Material	PP (UL 94-HB) & Flame Retardant (94-V0) available upon request
Weight (kg. / lb., Approx.)	36.90 / 81.33
Length (L) (mm / in)	343.0±2.5 / 13.50±0.10
Width (W) (mm / in)	170.0±2.0 / 6.69±0.0
Height (H) (mm / in)	216.6±2.5 / 8.53±0.10
Design Life	Up to 10 Years in Standby Service at 25°C Eurobat (20°C): >12 Years Very Long Life
Operating Temperature	Nominal: 25°C (77°F) Discharge: -15°C - 50°C (5°F-122°F) Charge/Storage: -15°C - 40°C (5°F - 104°F)
Float Charging Voltage	13.5 - 13.8 Vdc/battery 25°C (77°F)
Eq. Charging Voltage	14.4 - 15.0 Vdc/battery 25°C (77°F)
Self-Discharge	Less than 10% after 90 days, can be stored up to 6 months at 25°C (77°F); Fully recharging is required before usage, and charged sooner if stored at higher temperature than 25°C (77°F).



Valve Regulated Lead Acid (VRLA) Battery

Maintenance-Free, Absorbent Glass Mat (AGM) Technology for Efficient Gas Recombination of up to 99%

Pure Lead Construction and Proprietary Elements

Designed for High-Rate UPS, Float Service Standby Power Applications

Built in Accordance with IEC 60896-21/22:2004 and UL1989 Recognized (MH14533)





XHRL Series

XHRL 12500W Datasheet

12V Top Terminal VRLA-AGM

Constant Current Discharge Characteristics Unit: A (25°C, 77°F)

F.V/Time	2MIN	4MIN	5MIN	6MIN	8MIN	10MIN	15MIN	20MIN	30MIN	45MIN	60MIN	90MIN
10.02V (1.67 VPC)	700	567	512	472	401	350	264	210	151	107	83.5	58.9
10.50V (1.75 VPC)	592	486	449	412	359	317	247	199	146	104	81.7	58.1
10.80V (1.80 VPC)	514	434	397	369	324	288	231	187	139	100	79.3	57.1

Constant Power Discharge Characteristics Unit: W (25°C, 77°F)

F.V/Time	2MIN	4MIN	5MIN	6MIN	8MIN	10MIN	15MIN	20MIN	30MIN	45MIN	60MIN	90MIN
10.02V (1.67 VPC)	7118	5911	5473	5057	4377	3845	3017	2420	1774	1267	998	713
10.50V (1.75 VPC)	6352	5357	4941	4605	3986	3565	2847	2311	1722	1238	980	705
10.80V (1.80 VPC)	5765	4877	4516	4169	3676	3334	2677	2191	1652	1198	953	691

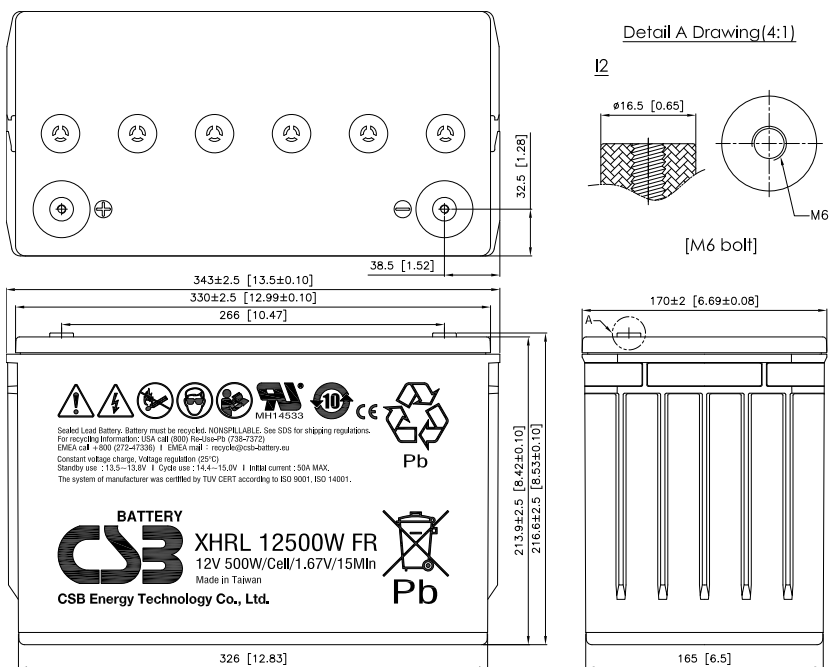



XHRL Series

XHRL 12650W Datasheet

12V Top Terminal VRLA-AGM

Specifications

Voltage (Vdc)	12
Nominal Capacity (1.67 VPC @25°C)	650W @15min-rate
Watts Per Cell (30-Sec 1.67 VPC @ 25°C)	--
Watts Per Cell (5-Min 1.67 VPC @ 25°)	1054.83
Watts Per Cell (15-Min 1.67 VPC @ 25°)	651.83
Max Charge Current (A)	65.00
Max Discharge Current (A)	1350
Short Circuit Current (A)	4018
Internal Resistance (mΩ)	Approx. 2.33
Terminal Type	12 thread lead alloy terminal to accept M6 bolt
Terminal Torque	51.7±10.3 Kgf·cm / 44.9±9.0 Lbf·in / 5.1±1.0 N·m
Container Material	PP (UL 94-HB) & Flame Retardant (94-V0) available upon request
Weight (kg. / lb., Approx.)	47.90 / 105.57
Length (L) (mm / in)	343.0±2.5 / 13.50±0.10
Width (W) (mm / in)	170.0±2.0 / 6.69±0.0
Height (H) (mm / in)	275.7±2.5 / 10.85±0.10
Design Life	Up to 10 Years in Standby Service at 25°C Eurobat (20°C): >12 Years Very Long Life
Operating Temperature	Nominal: 25°C (77°F) Discharge: -15°C - 50°C (5°F-122°F) Charge/Storage: -15°C - 40°C (5°F - 104°F)
Float Charging Voltage	13.5 - 13.8 Vdc/battery 25°C (77°F)
Eq. Charging Voltage	14.4 - 15.0 Vdc/battery 25°C (77°F)
Self-Discharge	Less than 10% after 90 days, can be stored up to 6 months at 25°C (77°F); Fully recharging is required before usage, and charged sooner if stored at higher temperature than 25°C (77°F).



Valve Regulated Lead Acid (VRLA) Battery

Maintenance-Free, Absorbent Glass Mat (AGM) Technology for Efficient Gas Recombination of up to 99%

Pure Lead Construction and Proprietary Elements

Designed for High-Rate UPS, Float Service Standby Power Applications

Built in Accordance with IEC 60896-21/22:2004 and UL1989 Recognized (MH14533)





XHRL Series

XHRL 12650W Datasheet

12V Top Terminal VRLA-AGM

Constant Current Discharge Characteristics Unit: A (25°C, 77°F)

F.V/Time	2MIN	4MIN	5MIN	6MIN	8MIN	10MIN	15MIN	20MIN	30MIN	45MIN	60MIN	90MIN
10.02V (1.67 VPC)	725	622	583	552	490	442	349	277	200	144	113	81.3
10.50V (1.75 VPC)	607	540	503	473	428	393	315	255	190	139	111	80.5
10.80V (1.80 VPC)	538	465	440	422	384	347	288	237	181	133	107	79.1

Constant Power Discharge Characteristics Unit: W (25°C, 77°F)

F.V/Time	2MIN	4MIN	5MIN	6MIN	8MIN	10MIN	15MIN	20MIN	30MIN	45MIN	60MIN	90MIN
10.02V (1.67 VPC)	7840	6754	6329	5959	5361	4882	3911	3179	2383	1740	1379	997
10.50V (1.75 VPC)	6857	6011	5718	5408	4894	4459	3623	2984	2278	1681	1342	981
10.80V (1.80 VPC)	6077	5461	5155	4917	4482	4083	3322	2776	2163	1612	1295	956

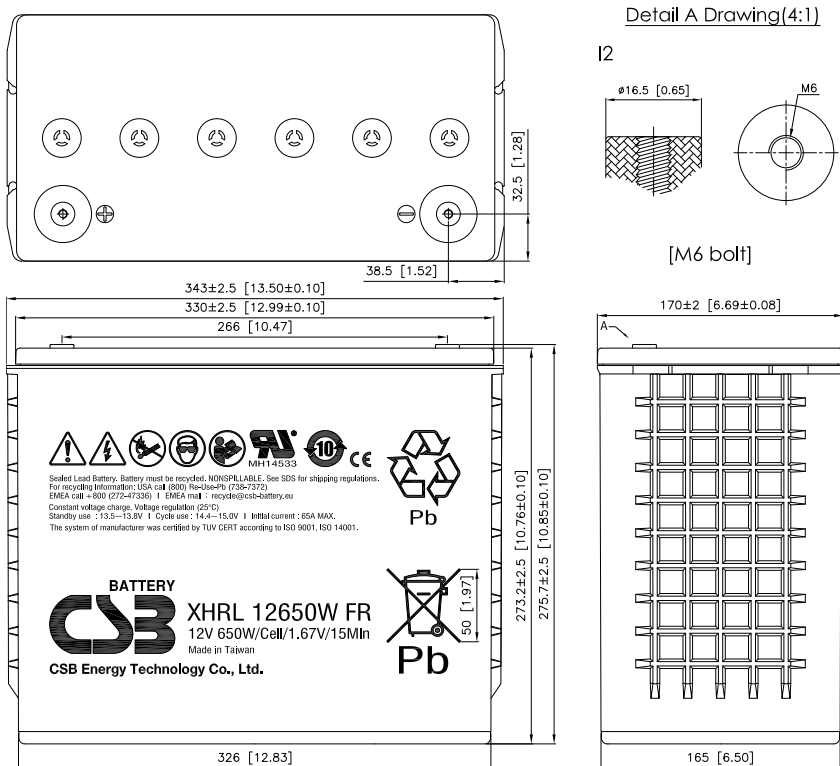



XHRL-FT Series

XHRL 12800WFT FR Datasheet

12V Front Terminal VRLA-AGM

Specifications

Voltage (Vdc)	12
Nominal Capacity (1.67 VPC @25°C)	800W @15min-rate
Watts Per Cell (30-Sec 1.67 VPC @ 25°C)	1831.17
Watts Per Cell (5-Min 1.67 VPC @ 25°)	1287.17
Watts Per Cell (15-Min 1.67 VPC @ 25°)	821.50
Max Charge Current (A)	80.00
Max Discharge Current (A)	1660
Short Circuit Current (A)	4570
Internal Resistance (mΩ)	Approx. 2.17
Terminal Type	12 thread lead alloy terminal to accept M6 bolt
Terminal Torque	51.7±10.3 Kgf·cm / 44.9±9.0 Lbf·in / 5.1±1.0 N·m
Container Material	PP (UL 94-HB) & Flame Retardant (94-V0) available upon request
Weight (kg. / lb., Approx.)	65.30 / 143.96
Length (L) (mm / in)	558.0±2.5 / 21.97±0.10
Width (W) (mm / in)	126.0±1.5 / 4.96±0.06
Height (H) (mm / in)	323.0±2.5 / 12.72±0.10
Design Life	Up to 10 Years in Standby Service at 25°C Eurobat (20°C): >12 Years Very Long Life
Operating Temperature	Nominal: 25°C (77°F) Discharge: -15°C - 50°C (5°F-122°F) Charge/Storage: -15°C - 40°C (5°F - 104°F)
Float Charging Voltage	13.5 - 13.8 Vdc/battery 25°C (77°F)
Eq. Charging Voltage	14.4 - 15.0 Vdc/battery 25°C (77°F)
Self-Discharge	Less than 10% after 90 days, can be stored up to 6 months at 25°C (77°F); Fully recharging is required before usage, and charged sooner if stored at higher temperature than 25°C (77°F).



Valve Regulated Lead Acid (VRLA) Battery

Maintenance-Free, Absorbent Glass Mat (AGM) Technology for Efficient Gas Recombination of up to 99%

Pure Lead Construction and Proprietary Elements

Designed for High-Rate UPS, Float Service Standby Power Applications

Built in Accordance with IEC 60896-21/22:2004 and UL1989 Recognized (MH14533)





XHRL-FT Series

XHRL 12800WFT FR Datasheet

12V Front Terminal VRLA-AGM

Constant Current Discharge Characteristics Unit: A (25°C, 77°F)

F.V/Time	30SEC	60SEC	2MIN	5MIN	8MIN	10MIN	15MIN	20MIN	30MIN	45MIN	60MIN	90MIN
10.02V (1.67 VPC)	1101	1037	940	749	627	572	458	384	282	204	159	113
10.50V (1.75 VPC)	784	761	739	625	551	497	408	353	264	197	156	111
10.80V (1.80 VPC)	619	598	577	550	478	438	373	320	244	187	149	107

Constant Power Discharge Characteristics Unit: W (25°C, 77°F)

F.V/Time	30SEC	60SEC	2MIN	5MIN	8MIN	10MIN	15MIN	20MIN	30MIN	45MIN	60MIN	90MIN
10.02V (1.67 VPC)	10987	10314	9370	7723	6710	6074	4929	4117	3070	2289	1820	1307
10.50V (1.75 VPC)	9088	8834	8124	6846	5920	5388	4541	3791	2897	2213	1763	1278
10.80V (1.80 VPC)	7338	7076	6823	6201	5280	4892	4171	3482	2720	2105	1688	1236

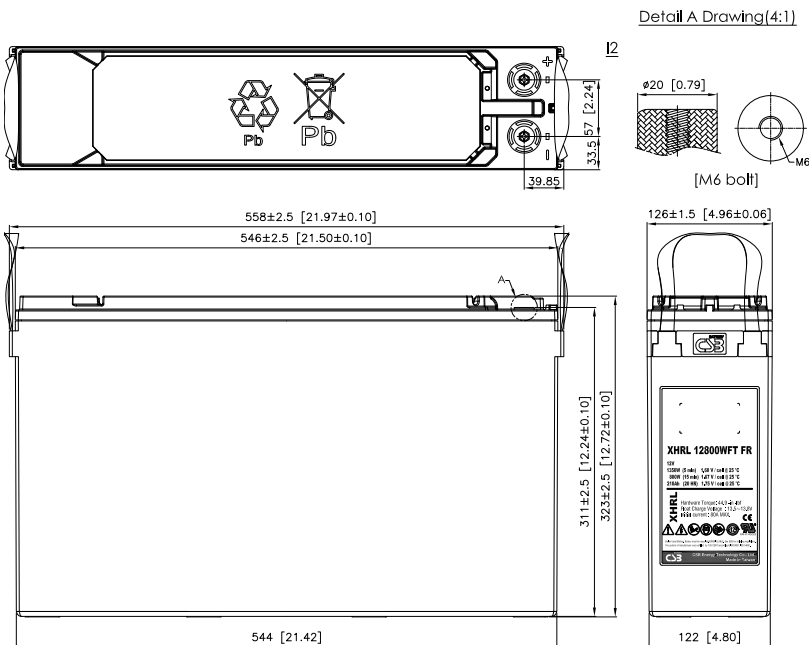



XHRL-FT Series

XHRL 12900WFT FR Datasheet

12V Front Terminal VRLA-AGM

Specifications

Voltage (Vdc)	12
Nominal Capacity (1.67 VPC @25°C)	900W @15min-rate
Watts Per Cell (30-Sec 1.67 VPC @ 25°C)	2069.83
Watts Per Cell (5-Min 1.67 VPC @ 25°)	1403.33
Watts Per Cell (15-Min 1.67 VPC @ 25°)	907.67
Max Charge Current (A)	90.00
Max Discharge Current (A)	1900
Short Circuit Current (A)	5102
Internal Resistance (mΩ)	Approx. 1.86
Terminal Type	12 thread lead alloy terminal to accept M6 bolt
Terminal Torque	51.7±10.3 Kgf·cm / 44.9±9.0 Lbf·in / 5.1±1.0 N·m
Container Material	PP (UL 94-HB) & Flame Retardant (94-V0) available upon request
Weight (kg. / lb., Approx.)	69.50 / 153.22
Length (L) (mm / in)	558.0±2.5 / 21.97±0.10
Width (W) (mm / in)	126.0±1.5 / 4.96±0.06
Height (H) (mm / in)	323.0±2.5 / 12.72±0.10
Design Life	Up to 10 Years in Standby Service at 25°C Eurobat (20°C): >12 Years Very Long Life
Operating Temperature	Nominal: 25°C (77°F) Discharge: -15°C - 50°C (5°F-122°F) Charge/Storage: -15°C - 40°C (5°F - 104°F)
Float Charging Voltage	13.5 - 13.8 Vdc/battery 25°C (77°F)
Eq. Charging Voltage	14.4 - 15.0 Vdc/battery 25°C (77°F)
Self-Discharge	Less than 10% after 90 days, can be stored up to 6 months at 25°C (77°F); Fully recharging is required before usage, and charged sooner if stored at higher temperature than 25°C (77°F).



Valve Regulated Lead Acid (VRLA) Battery

Maintenance-Free, Absorbent Glass Mat (AGM) Technology for Efficient Gas Recombination of up to 99%

Pure Lead Construction and Proprietary Elements

Designed for High-Rate UPS, Float Service Standby Power Applications

Built in Accordance with IEC 60896-21/22:2004 and UL1989 Recognized (MH14533)





XHRL-FT Series

XHRL 12900WFT FR Datasheet

12V Front Terminal VRLA-AGM

Constant Current Discharge Characteristics Unit: A (25°C, 77°F)

F.V/Time	30SEC	60SEC	2MIN	5MIN	8MIN	10MIN	15MIN	20MIN	30MIN	45MIN	60MIN	90MIN
10.02V (1.67 VPC)	1221	1128	1041	842	698	635	506	407	291	208	160	112
10.50V (1.75 VPC)	887	862	838	710	622	558	458	371	273	200	156	110
10.80V (1.80 VPC)	770	742	715	626	546	498	420	337	254	189	149	106

Constant Power Discharge Characteristics Unit: W (25°C, 77°F)

F.V/Time	30SEC	60SEC	2MIN	5MIN	8MIN	10MIN	15MIN	20MIN	30MIN	45MIN	60MIN	90MIN
10.02V (1.67 VPC)	12419	11562	10445	8420	7376	6629	5446	4488	3285	2399	1896	1361
10.50V (1.75 VPC)			8950	7634	6603	5992	5007	4094	3094	2316	1842	1334
10.80V (1.80 VPC)			7655	7148	6008	5546	4664	3748	2909	2207	1769	1295

Detail A Drawing(4:1)

