



EVX Series

EVX 1272 Datasheet

12V Top Terminal VRLA-AGM



Valve Regulated Lead Acid (VRLA) Battery

Maintenance-Free, Absorbent Glass Mat (AGM) Technology for Efficient Gas Recombination of up to 99%

Pure Lead Construction and Proprietary Elements

Designed for E-mobility or deep cycling applications

Built in Accordance with IEC 60254-1:2005 / IEC60254-2:2008 and UL1989 Recognized (MH14533)



Specifications

Voltage (Vdc)	12
Nominal Capacity (1.75 VPC @25°C)	7.2 Ah @20hr-rate
Ah Capacity (8-Hr 1.75 VPC @ 25°C)	6.00
Ah Capacity (20-Hr 1.75 VPC @ 25°C)	7.20
Ah Capacity (8-Hr 1.80 VPC @ 25°C)	5.76
Max Charge Current (A)	2.16
Max Discharge Current (A)	130 *
Short Circuit Current (A)	292
Internal Resistance (mΩ)	Approx. 23.9
Terminal Type	F2 terminal -Faston Tab 250 *
Terminal Torque	--
Container Material	ABS (UL 94-HB)
Weight (kg. / lb., Approx.)	2.55 / 5.62
Length (L) (mm / in)	150.9±2.0 / 5.94±0.08
Width (W) (mm / in)	64.8±1.0 / 2.55±0.04
Height (H) (mm / in)	98.6±1.0 / 3.88±0.04
Design Life	400 cycles @ 100%DOD at 25°C 1800 cycles @ 30%DOD at 25°C
Operating Temperature	Nominal: 25°C (77°F) Discharge: -15°C - 50°C (5°F-122°F) Charge/Storage: -15°C - 40°C (5°F - 104°F)
Float Charging Voltage	--
Eq. Charging Voltage	14.4 - 15.0 Vdc/battery 25°C (77°F)
Self-Discharge	Less than 10% after 90 days, can be stored up to 6 months at 25°C (77°F); Fully recharging is required before usage, and charged sooner if stored at higher temperature than 25°C (77°F).



EVX Series

EVX 1272 Datasheet

12V Top Terminal VRLA-AGM

Constant Current Discharge Characteristics Unit: A (25°C, 77°F)

F.V/Time	30MIN	45MIN	60MIN	90MIN	2HR	3HR	4HR	5HR	6HR	8HR	10HR	20HR
10.02V (1.67 VPC)	6.79	5.01	4.04	2.98	2.40	1.73	1.39	1.16	1.00	0.79	0.65	0.38
10.50V (1.75 VPC)	6.38	4.71	3.80	2.81	2.27	1.63	1.32	1.10	0.95	0.75	0.62	0.36
10.80V (1.80 VPC)	6.20	4.58	3.70	2.73	2.19	1.58	1.28	1.07	0.92	0.72	0.60	0.35

Constant Power Discharge Characteristics Unit: W (25°C, 77°F)

F.V/Time	30MIN	45MIN	60MIN	90MIN	2HR	3HR	4HR	5HR	6HR	8HR	10HR	20HR
10.02V (1.67 VPC)	81.4	60.3	48.8	35.8	28.8	20.9	16.8	14.0	12.0	9.50	7.86	4.35
10.50V (1.75 VPC)	76.8	56.8	45.9	33.8	27.1	19.6	15.8	13.2	11.4	8.96	7.49	4.14
10.80V (1.80 VPC)	74.4	55.0	44.4	32.7	26.2	19.0	15.3	12.8	11.0	8.67	7.25	4.00

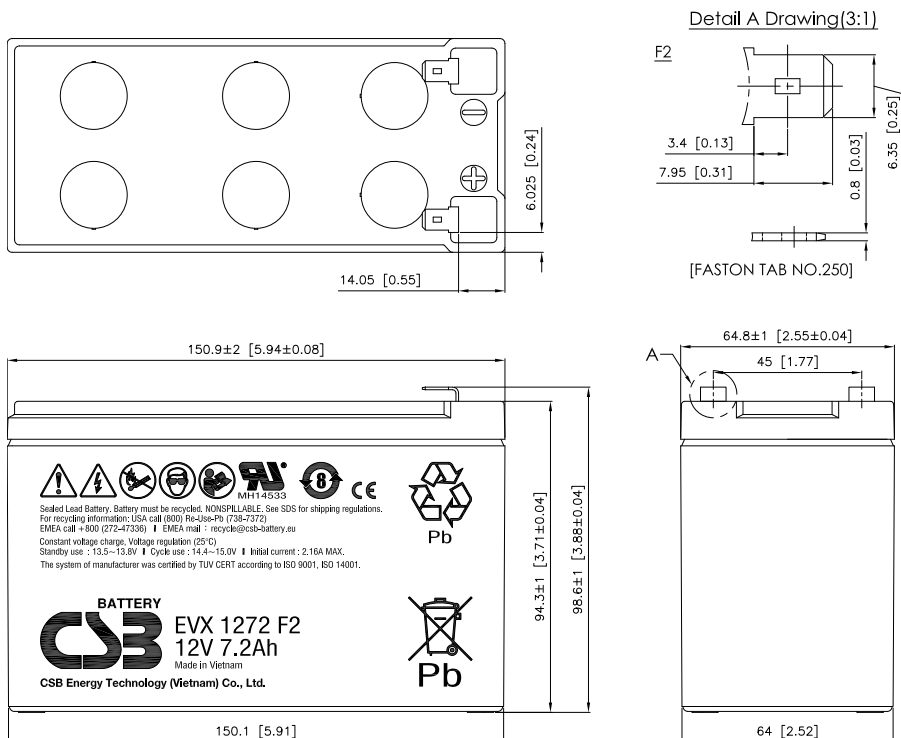

* F1 terminal is available, Max Discharge Current = 100 A (5sec)



EVX Series

EVX 12120 Datasheet

12V Top Terminal VRLA-AGM



Valve Regulated Lead Acid (VRLA) Battery

Maintenance-Free, Absorbent Glass Mat (AGM) Technology for Efficient Gas Recombination of up to 99%

Pure Lead Construction and Proprietary Elements

Designed for E-mobility or deep cycling applications

Built in Accordance with IEC 60254-1:2005 / IEC60254-2:2008 and UL1989 Recognized (MH14533)



Specifications

Voltage (Vdc)	12
Nominal Capacity (1.75 VPC @25°C)	12 Ah @20hr-rate
Ah Capacity (8-Hr 1.75 VPC @ 25°C)	10.64
Ah Capacity (20-Hr 1.75 VPC @ 25°C)	12.00
Ah Capacity (8-Hr 1.80 VPC @ 25°C)	10.56
Max Charge Current (A)	3.60
Max Discharge Current (A)	180 *
Short Circuit Current (A)	464
Internal Resistance (mΩ)	Approx. 15.4
Terminal Type	F2 terminal -Faston Tab 250 *
Terminal Torque	--
Container Material	ABS (UL 94-HB)
Weight (kg. / lb., Approx.)	3.83 / 8.44
Length (L) (mm / in)	151.0±2.0 / 5.94±0.08
Width (W) (mm / in)	98.0±1.0 / 3.86±0.04
Height (H) (mm / in)	100.3±1.5 / 3.95±0.06
Design Life	400 cycles @ 100%DOD at 25°C 1800 cycles @ 30%DOD at 25°C
Operating Temperature	Nominal: 25°C (77°F) Discharge: -15°C - 50°C (5°F-122°F) Charge/Storage: -15°C - 40°C (5°F - 104°F)
Float Charging Voltage	--
Eq. Charging Voltage	14.4 - 15.0 Vdc/battery 25°C (77°F)
Self-Discharge	Less than 10% after 90 days, can be stored up to 6 months at 25°C (77°F); Fully recharging is required before usage, and charged sooner if stored at higher temperature than 25°C (77°F).



EVX Series

EVX 12120 Datasheet

12V Top Terminal VRLA-AGM

Constant Current Discharge Characteristics Unit: A (25°C, 77°F)

F.V/Time	30MIN	45MIN	60MIN	90MIN	2HR	3HR	4HR	5HR	6HR	8HR	10HR	20HR
10.02V (1.67 VPC)	12.7	9.30	7.45	5.45	4.29	3.10	2.44	2.05	1.74	1.35	1.12	0.63
10.50V (1.75 VPC)	12.4	9.14	7.36	5.36	4.25	3.07	2.41	2.01	1.71	1.33	1.09	0.60
10.80V (1.80 VPC)	12.0	8.89	7.18	5.28	4.17	3.00	2.38	1.99	1.70	1.32	1.07	0.59

Constant Power Discharge Characteristics Unit: W (25°C, 77°F)

F.V/Time	30MIN	45MIN	60MIN	90MIN	2HR	3HR	4HR	5HR	6HR	8HR	10HR	20HR
10.02V (1.67 VPC)	146	107	85.7	62.9	50.1	36.6	29.1	24.3	20.7	16.1	13.3	7.09
10.50V (1.75 VPC)	143	105	84.9	62.3	49.5	36.2	28.8	23.9	20.4	15.9	13.1	7.01
10.80V (1.80 VPC)	140	103	83.5	61.2	49.0	35.7	28.5	23.7	20.2	15.7	12.9	6.87

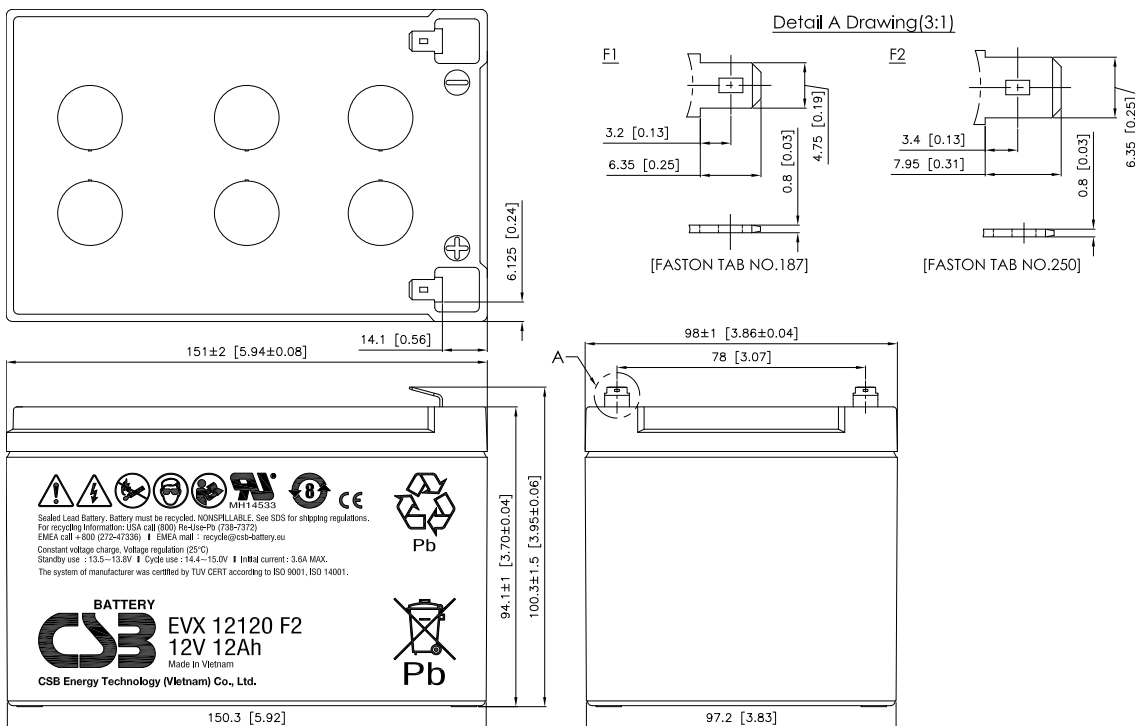

* F1 terminal is available, Max Discharge Current = 150 A (5sec)



EVX Series

EVX 12170 Datasheet

12V Top Terminal VRLA-AGM

Specifications

Voltage (Vdc)	12
Nominal Capacity (1.75 VPC @25°C)	17 Ah @20hr-rate
Ah Capacity (8-Hr 1.75 VPC @ 25°C)	14.48
Ah Capacity (20-Hr 1.75 VPC @ 25°C)	17.00
Ah Capacity (8-Hr 1.80 VPC @ 25°C)	14.00
Max Charge Current (A)	5.10
Max Discharge Current (A)	230
Short Circuit Current (A)	536
Internal Resistance (mΩ)	Approx. 13.3
Terminal Type	B1/B1B/B3 terminal to accept M5 bolt
Terminal Torque	30.4±6.1 Kg·cm / 26.4±5.3 Lbf·in / 3.0±0.6 N·m
Container Material	ABS (UL 94-HB)
Weight (kg. / lb., Approx.)	5.67 / 12.50
Length (L) (mm / in)	181.0±2.0 / 7.13±0.08
Width (W) (mm / in)	76.2±1.0 / 3.00±0.04
Height (H) (mm / in)	167.0±2.0 / 6.57±0.08
Design Life	400 cycles @ 100%DOD at 25°C 1800 cycles @ 30%DOD at 25°C
Operating Temperature	Nominal: 25°C (77°F) Discharge: -15°C - 50°C (5°F-122°F) Charge/Storage: -15°C - 40°C (5°F - 104°F)
Float Charging Voltage	--
Eq. Charging Voltage	14.4 - 15.0 Vdc/battery 25°C (77°F)
Self-Discharge	Less than 10% after 90 days, can be stored up to 6 months at 25°C (77°F); Fully recharging is required before usage, and charged sooner if stored at higher temperature than 25°C (77°F).



Valve Regulated Lead Acid (VRLA) Battery

Maintenance-Free, Absorbent Glass Mat (AGM) Technology for Efficient Gas Recombination of up to 99%

Pure Lead Construction and Proprietary Elements

Designed for E-mobility or deep cycling applications

Built in Accordance with IEC 60254-1:2005 / IEC60254-2:2008 and UL1989 Recognized (MH14533)





EVX Series

EVX 12170 Datasheet

12V Top Terminal VRLA-AGM

Constant Current Discharge Characteristics Unit: A (25°C, 77°F)

F.V/Time	30MIN	45MIN	60MIN	90MIN	2HR	3HR	4HR	5HR	6HR	8HR	10HR	20HR
10.02V (1.67 VPC)	16.5	12.3	9.94	7.14	5.77	4.28	3.43	2.84	2.44	1.92	1.58	0.90
10.50V (1.75 VPC)	15.5	11.6	9.38	6.70	5.43	4.04	3.24	2.68	2.30	1.81	1.49	0.85
10.80V (1.80 VPC)	15.0	11.2	9.08	6.48	5.25	3.91	3.14	2.59	2.22	1.75	1.44	0.83

Constant Power Discharge Characteristics Unit: W (25°C, 77°F)

F.V/Time	30MIN	45MIN	60MIN	90MIN	2HR	3HR	4HR	5HR	6HR	8HR	10HR	20HR
10.02V (1.67 VPC)	198	148	120	85.5	69.5	51.3	41.3	34.1	29.3	23.1	18.8	10.4
10.50V (1.75 VPC)	186	139	113	80.4	65.5	48.4	38.9	32.1	27.6	21.7	17.9	9.90
10.80V (1.80 VPC)	180	134	109	77.8	63.3	46.9	37.7	31.1	26.7	21.0	17.3	9.59

Detail A Drawing(3:1)

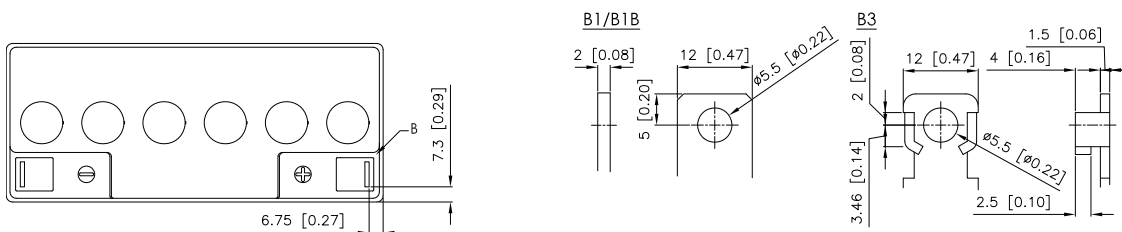

Detail B Drawing(1:1)

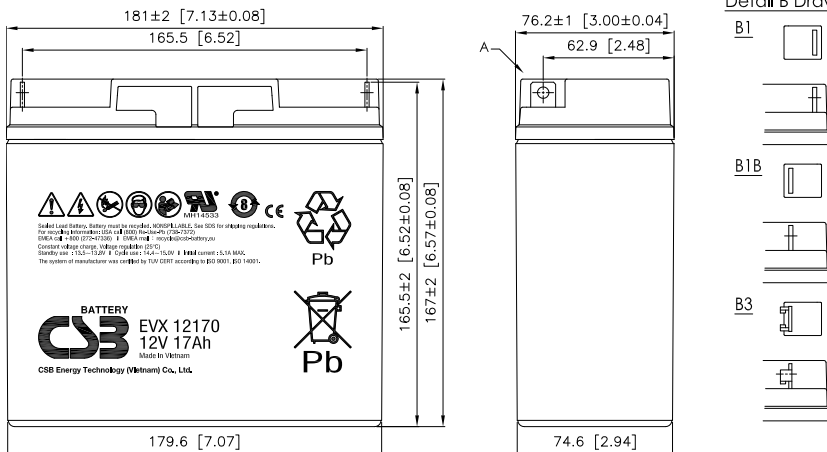

BATTERY EVX 12170
 12V 17Ah
 Made in Vietnam
 CSB Energy Technology (Vietnam) Co., Ltd.



EVX Series

EVX 12200 Datasheet

12V Top Terminal VRLA-AGM

Specifications

Voltage (Vdc)	12
Nominal Capacity (1.75 VPC @25°C)	20 Ah @20hr-rate
Ah Capacity (8-Hr 1.75 VPC @ 25°C)	16.96
Ah Capacity (20-Hr 1.75 VPC @ 25°C)	20.00
Ah Capacity (8-Hr 1.80 VPC @ 25°C)	16.24
Max Charge Current (A)	6.00
Max Discharge Current (A)	230
Short Circuit Current (A)	607
Internal Resistance (mΩ)	Approx. 13.5
Terminal Type	I1 terminal to accept M5 bolt
Terminal Torque	30.4±6.1 Kgf·cm / 26.4±5.3 Lbf·in / 3.0±0.6 N·m
Container Material	ABS (UL 94-HB)
Weight (kg. / lb., Approx.)	6.55 / 14.44
Length (L) (mm / in)	181.0±2.0 / 7.12±0.08
Width (W) (mm / in)	76.0±1.0 / 2.99±0.04
Height (H) (mm / in)	165.0±2.0 / 6.50±0.08
Design Life	400 cycles @ 100%DOD at 25°C 1800 cycles @ 30%DOD at 25°C
Operating Temperature	Nominal: 25°C (77°F) Discharge: -15°C - 50°C (5°F-122°F) Charge/Storage: -15°C - 40°C (5°F - 104°F)
Float Charging Voltage	--
Eq. Charging Voltage	14.4 - 15.0 Vdc/battery 25°C (77°F)
Self-Discharge	Less than 10% after 90 days, can be stored up to 6 months at 25°C (77°F); Fully recharging is required before usage, and charged sooner if stored at higher temperature than 25°C (77°F).



Valve Regulated Lead Acid (VRLA) Battery

Maintenance-Free, Absorbent Glass Mat (AGM) Technology for Efficient Gas Recombination of up to 99%

Pure Lead Construction and Proprietary Elements

Designed for E-mobility or deep cycling applications

Built in Accordance with IEC 60254-1:2005 / IEC60254-2:2008 and UL1989 Recognized (MH14533)





EVX Series

EVX 12200 Datasheet

12V Top Terminal VRLA-AGM

Constant Current Discharge Characteristics Unit: A (25°C, 77°F)

F.V/Time	30MIN	45MIN	60MIN	90MIN	2HR	3HR	4HR	5HR	6HR	8HR	10HR	20HR
10.02V (1.67 VPC)	20.0	15.0	12.3	8.99	7.25	5.15	4.10	3.35	2.86	2.23	1.85	1.06
10.50V (1.75 VPC)	18.9	14.2	11.6	8.50	6.79	4.85	3.85	3.16	2.71	2.12	1.75	1.00
10.80V (1.80 VPC)	18.2	13.6	11.1	8.17	6.50	4.68	3.69	3.03	2.59	2.03	1.68	0.96

Constant Power Discharge Characteristics Unit: W (25°C, 77°F)

F.V/Time	30MIN	45MIN	60MIN	90MIN	2HR	3HR	4HR	5HR	6HR	8HR	10HR	20HR
10.02V (1.67 VPC)	240	180	147	108	86.2	61.6	48.9	40.2	34.3	26.8	22.0	11.9
10.50V (1.75 VPC)	226	169	138	101	80.6	58.1	45.9	37.6	32.2	25.2	20.8	11.3
10.80V (1.80 VPC)	218	163	133	98.0	77.4	56.1	44.3	36.3	31.1	24.3	20.1	10.8

Detail A Drawing(3:1)

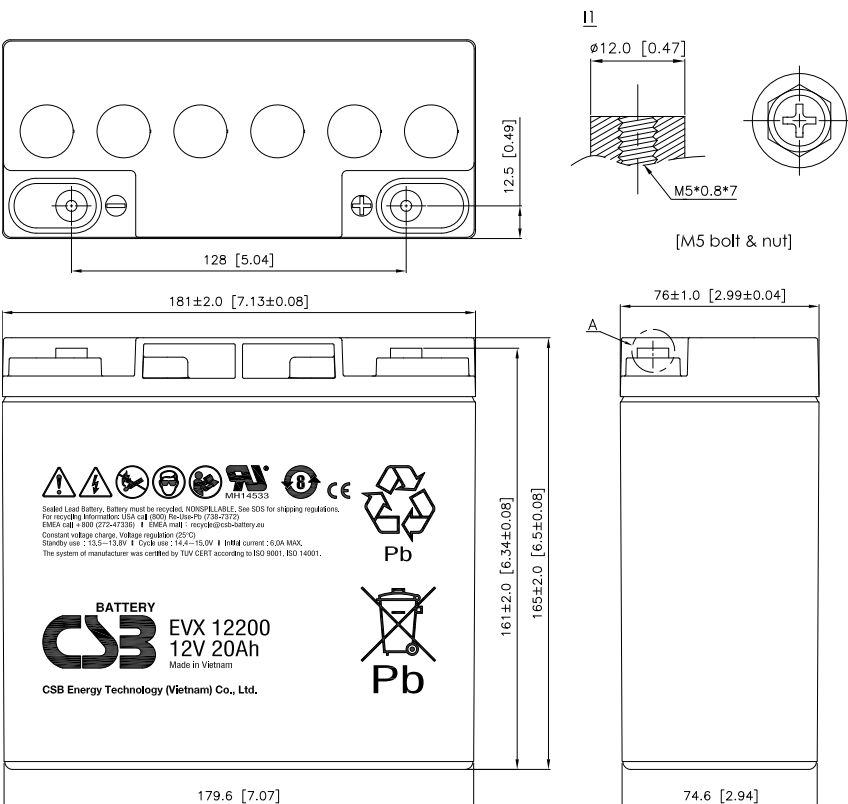



EVX Series

EVX 12260 Datasheet

12V Top Terminal VRLA-AGM

Specifications

Voltage (Vdc)	12
Nominal Capacity (1.75 VPC @25°C)	26 Ah @20hr-rate
Ah Capacity (8-Hr 1.75 VPC @ 25°C)	23.28
Ah Capacity (20-Hr 1.75 VPC @ 25°C)	26.60
Ah Capacity (8-Hr 1.80 VPC @ 25°C)	22.48
Max Charge Current (A)	7.80
Max Discharge Current (A)	350
Short Circuit Current (A)	797
Internal Resistance (mΩ)	Approx. 9.6
Terminal Type	11 thread lead alloy terminal to accept M5 bolt
Terminal Torque	30.4±6.1 Kgf·cm / 26.4±5.3 Lbf·in / 3.0±0.6 N·m
Container Material	ABS (UL 94-HB)
Weight (kg. / lb., Approx.)	8.65 / 19.06
Length (L) (mm / in)	166.0±2.0 / 6.54±0.08
Width (W) (mm / in)	175.0±2.0 / 6.89±0.08
Height (H) (mm / in)	125.0±1.5 / 4.92±0.06
Design Life	400 cycles @ 100%DOD at 25°C 1800 cycles @ 30%DOD at 25°C
Operating Temperature	Nominal: 25°C (77°F) Discharge: -15°C - 50°C (5°F-122°F) Charge/Storage: -15°C - 40°C (5°F - 104°F)
Float Charging Voltage	--
Eq. Charging Voltage	14.4 - 15.0 Vdc/battery 25°C (77°F)
Self-Discharge	Less than 10% after 90 days, can be stored up to 6 months at 25°C (77°F); Fully recharging is required before usage, and charged sooner if stored at higher temperature than 25°C (77°F).



Valve Regulated Lead Acid (VRLA) Battery

Maintenance-Free, Absorbent Glass Mat (AGM) Technology for Efficient Gas Recombination of up to 99%

Pure Lead Construction and Proprietary Elements

Designed for E-mobility or deep cycling applications

Built in Accordance with IEC 60254-1:2005 / IEC60254-2:2008 and UL1989 Recognized (MH14533)





EVX Series

EVX 12260 Datasheet

12V Top Terminal VRLA-AGM

Constant Current Discharge Characteristics Unit: A (25°C, 77°F)

F.V/Time	30MIN	45MIN	60MIN	90MIN	2HR	3HR	4HR	5HR	6HR	8HR	10HR	20HR
10.02V (1.67 VPC)	26.5	19.7	16.0	11.4	9.22	6.82	5.49	4.56	3.92	3.09	2.56	1.41
10.50V (1.75 VPC)	24.9	18.5	15.0	10.8	8.68	6.39	5.16	4.30	3.70	2.91	2.40	1.33
10.80V (1.80 VPC)	24.1	18.0	14.6	10.4	8.41	6.19	5.00	4.16	3.57	2.81	2.32	1.28

Constant Power Discharge Characteristics Unit: W (25°C, 77°F)

F.V/Time	30MIN	45MIN	60MIN	90MIN	2HR	3HR	4HR	5HR	6HR	8HR	10HR	20HR
10.02V (1.67 VPC)	318	237	192	137	111	81.4	65.7	54.6	47.0	37.2	30.6	16.9
10.50V (1.75 VPC)	299	223	181	129	104	76.7	61.9	51.6	44.3	34.9	28.8	15.9
10.80V (1.80 VPC)	289	216	175	125	101	74.3	60.0	49.9	42.9	33.7	27.8	15.4

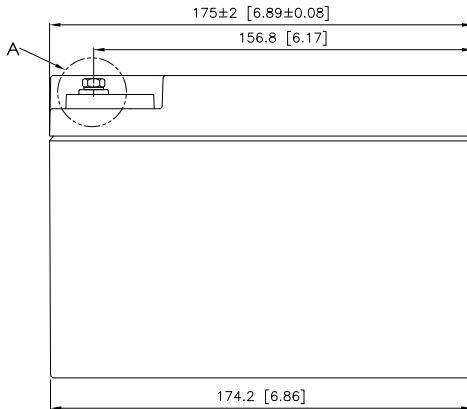
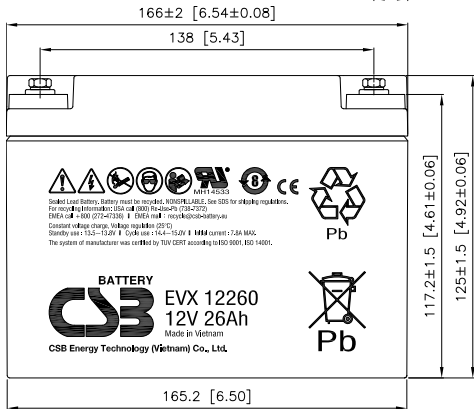
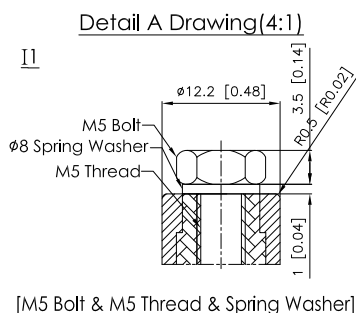
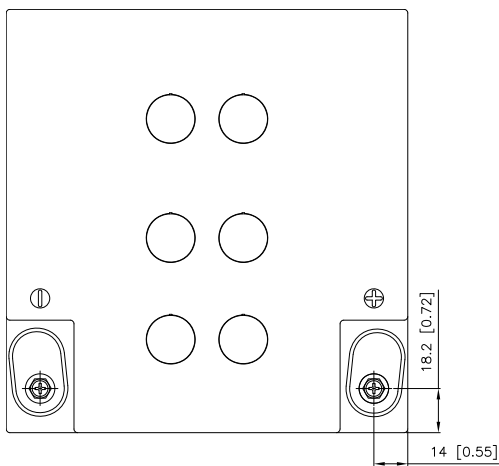



EVX Series

EVX 12300 Datasheet

12V Top Terminal VRLA-AGM

Specifications

Voltage (Vdc)	12
Nominal Capacity (1.75 VPC @25°C)	30 Ah @20hr-rate
Ah Capacity (8-Hr 1.75 VPC @ 25°C)	24.96
Ah Capacity (20-Hr 1.75 VPC @ 25°C)	30.00
Ah Capacity (8-Hr 1.80 VPC @ 25°C)	24.32
Max Charge Current (A)	9.00
Max Discharge Current (A)	400
Short Circuit Current (A)	905
Internal Resistance (mΩ)	Approx. 7.9
Terminal Type	I1 terminal to accept M5 bolt
Terminal Torque	30.4±6.1 Kgf·cm / 26.4±5.3 Lbf·in / 3.0±0.6 N·m
Container Material	ABS (UL 94-HB)
Weight (kg. / lb., Approx.)	10.40 / 22.92
Length (L) (mm / in)	166.0±2.0 / 6.54±0.08
Width (W) (mm / in)	125.0±1.5 / 4.92±0.06
Height (H) (mm / in)	175.0±2.0 / 6.89±0.08
Design Life	400 cycles @ 100%DOD at 25°C 1800 cycles @ 30%DOD at 25°C
Operating Temperature	Nominal: 25°C (77°F) Discharge: -15°C - 50°C (5°F-122°F) Charge/Storage: -15°C - 40°C (5°F - 104°F)
Float Charging Voltage	--
Eq. Charging Voltage	14.4 - 15.0 Vdc/battery 25°C (77°F)
Self-Discharge	Less than 10% after 90 days, can be stored up to 6 months at 25°C (77°F); Fully recharging is required before usage, and charged sooner if stored at higher temperature than 25°C (77°F).



Valve Regulated Lead Acid (VRLA) Battery

Maintenance-Free, Absorbent Glass Mat (AGM) Technology for Efficient Gas Recombination of up to 99%

Pure Lead Construction and Proprietary Elements

Designed for E-mobility or deep cycling applications

Built in Accordance with IEC 60254-1:2005 / IEC60254-2:2008 and UL1989 Recognized (MH14533)





EVX Series

EVX 12300 Datasheet

12V Top Terminal VRLA-AGM

Constant Current Discharge Characteristics Unit: A (25°C, 77°F)

F.V/Time	30MIN	45MIN	60MIN	90MIN	2HR	3HR	4HR	5HR	6HR	8HR	10HR	20HR
10.02V (1.67 VPC)	30.6	21.9	17.3	12.3	9.94	7.26	5.87	4.90	4.20	3.29	2.75	1.58
10.50V (1.75 VPC)	29.2	20.8	16.3	11.6	9.38	6.83	5.54	4.64	3.98	3.12	2.61	1.50
10.80V (1.80 VPC)	28.4	20.2	15.8	11.3	9.07	6.61	5.37	4.51	3.87	3.04	2.53	1.45

Constant Power Discharge Characteristics Unit: W (25°C, 77°F)

F.V/Time	30MIN	45MIN	60MIN	90MIN	2HR	3HR	4HR	5HR	6HR	8HR	10HR	20HR
10.02V (1.67 VPC)	367	263	207	147	120	87.1	70.4	58.6	50.1	39.1	32.2	16.8
10.50V (1.75 VPC)	351	250	196	139	112	81.9	66.4	55.6	47.5	37.0	30.5	15.9
10.80V (1.80 VPC)	341	242	190	135	109	79.3	64.4	54.1	46.1	35.9	29.5	15.4

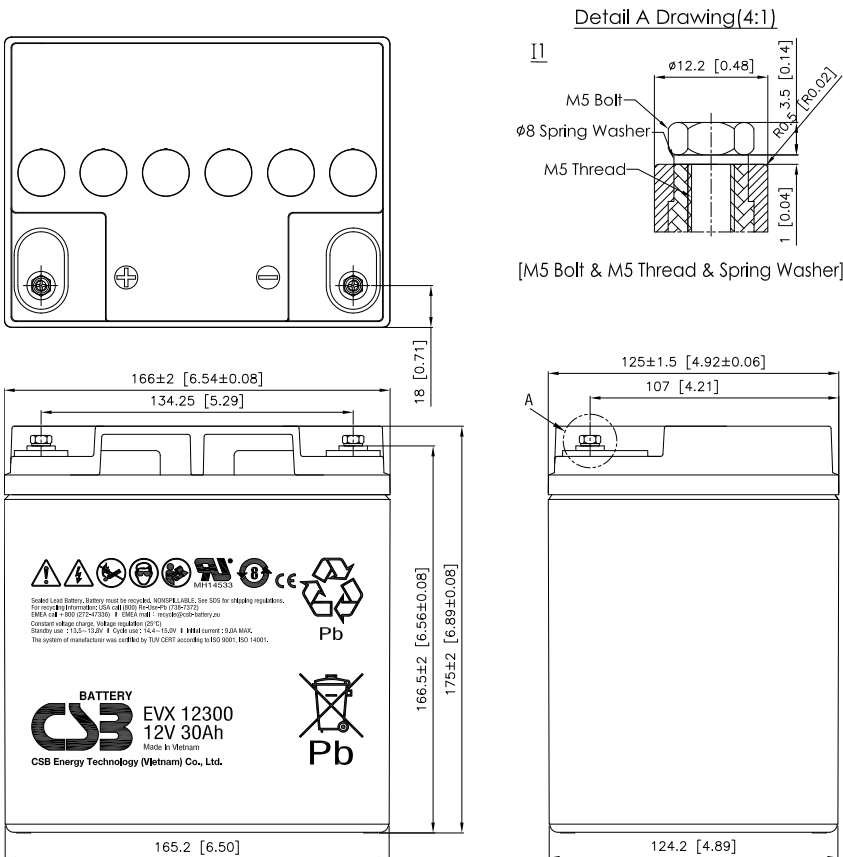



EVX Series

EVX 12340 Datasheet

12V Top Terminal VRLA-AGM



Valve Regulated Lead Acid (VRLA) Battery

Maintenance-Free, Absorbent Glass Mat (AGM) Technology for Efficient Gas Recombination of up to 99%

Pure Lead Construction and Proprietary Elements

Designed for E-mobility or deep cycling applications

Built in Accordance with IEC 60254-1:2005 / IEC60254-2:2008 and UL1989 Recognized (MH14533)



Specifications

Voltage (Vdc)	12
Nominal Capacity (1.75 VPC @25°C)	34 Ah @20hr-rate
Ah Capacity (8-Hr 1.75 VPC @ 25°C)	27.68
Ah Capacity (20-Hr 1.75 VPC @ 25°C)	34.40
Ah Capacity (8-Hr 1.80 VPC @ 25°C)	27.28
Max Charge Current (A)	10.20
Max Discharge Current (A)	400
Short Circuit Current (A)	849
Internal Resistance (mΩ)	Approx. 9.2
Terminal Type	B5 terminal to accept M6 nut & bolt
Terminal Torque	51.7±10.3 Kgf·cm / 44.9±9.0 Lbf·in / 5.1±1.0 N·m
Container Material	ABS (UL 94-HB)
Weight (kg. / lb., Approx.)	10.77 / 23.74
Length (L) (mm / in)	195.6±2.0 / 7.70±0.08
Width (W) (mm / in)	130.0±1.5 / 5.12±0.06
Height (H) (mm / in)	178.3±2.0 / 7.02±0.08
Design Life	400 cycles @ 100%DOD at 25°C 1800 cycles @ 30%DOD at 25°C
Operating Temperature	Nominal: 25°C (77°F) Discharge: -15°C - 50°C (5°F-122°F) Charge/Storage: -15°C - 40°C (5°F - 104°F)
Float Charging Voltage	--
Eq. Charging Voltage	14.4 - 15.0 Vdc/battery 25°C (77°F)
Self-Discharge	Less than 10% after 90 days, can be stored up to 6 months at 25°C (77°F); Fully recharging is required before usage, and charged sooner if stored at higher temperature than 25°C (77°F).



EVX Series

EVX 12340 Datasheet

12V Top Terminal VRLA-AGM

Constant Current Discharge Characteristics Unit: A (25°C, 77°F)

F.V/Time	30MIN	45MIN	60MIN	90MIN	2HR	3HR	4HR	5HR	6HR	8HR	10HR	20HR
10.02V (1.67 VPC)	33.6	24.7	19.8	14.5	11.5	8.19	6.49	5.34	4.57	3.57	3.02	1.80
10.50V (1.75 VPC)	31.8	23.6	19.1	14.0	11.2	8.02	6.36	5.22	4.45	3.46	2.90	1.72
10.80V (1.80 VPC)	30.8	23.0	18.7	13.8	11.0	7.86	6.27	5.14	4.38	3.41	2.86	1.69

Constant Power Discharge Characteristics Unit: W (25°C, 77°F)

F.V/Time	30MIN	45MIN	60MIN	90MIN	2HR	3HR	4HR	5HR	6HR	8HR	10HR	20HR
10.02V (1.67 VPC)	404	296	238	173	139	98.3	78.0	64.1	54.8	42.8	35.3	19.0
10.50V (1.75 VPC)	382	283	229	168	135	96.3	76.5	62.6	53.4	41.5	33.9	18.0
10.80V (1.80 VPC)	370	276	224	165	132	95.1	75.5	61.8	52.7	40.9	33.4	17.6

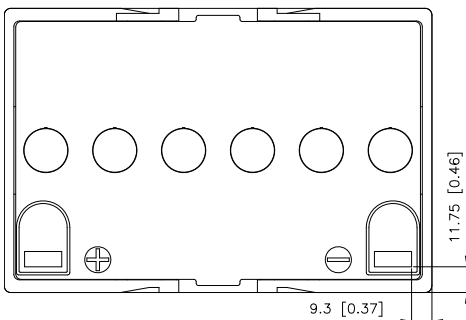

Detail A Drawing(3:1)

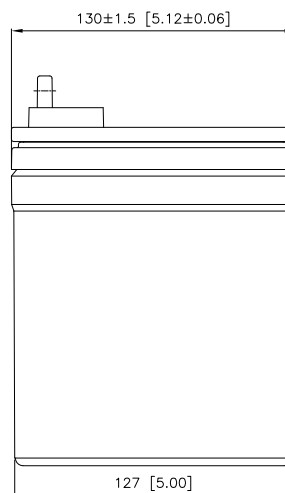
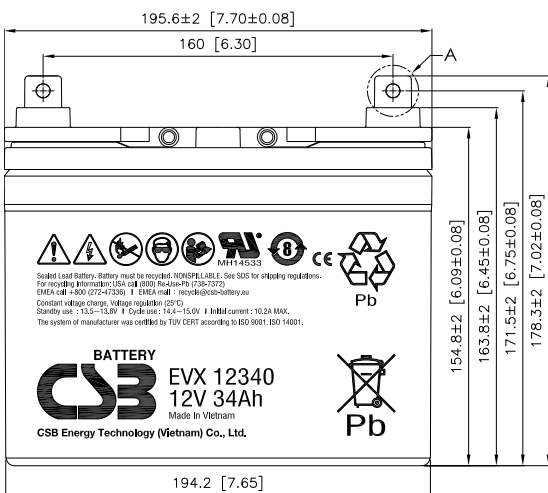
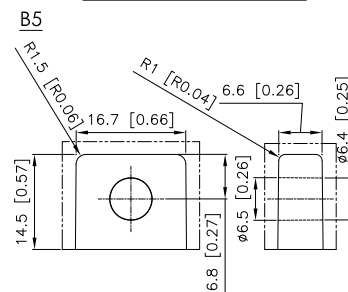



EVX Series

EVX 12400 Datasheet

12V Top Terminal VRLA-AGM

Specifications

Voltage (Vdc)	12
Nominal Capacity (1.75 VPC @25°C)	40 Ah @20hr-rate
Ah Capacity (8-Hr 1.75 VPC @ 25°C)	31.52
Ah Capacity (20-Hr 1.75 VPC @ 25°C)	40.00
Ah Capacity (8-Hr 1.80 VPC @ 25°C)	30.56
Max Charge Current (A)	12.00
Max Discharge Current (A)	400
Short Circuit Current (A)	1082
Internal Resistance (mΩ)	Approx. 8.2
Terminal Type	I2 terminal to accept M6 bolt
Terminal Torque	51.7±10.3 Kgf·cm / 44.9±9.0 Lbf·in / 5.1±1.0 N·m
Container Material	ABS (UL 94-HB)
Weight (kg. / lb., Approx.)	13.20 / 29.07
Length (L) (mm / in)	197.0±2.0 / 7.76±0.08
Width (W) (mm / in)	165.0±2.0 / 6.50±0.08
Height (H) (mm / in)	170.4±2.0 / 6.71±0.08
Design Life	400 cycles @ 100%DOD at 25°C 1800 cycles @ 30%DOD at 25°C
Operating Temperature	Nominal: 25°C (77°F) Discharge: -15°C - 50°C (5°F-122°F) Charge/Storage: -15°C - 40°C (5°F - 104°F)
Float Charging Voltage	--
Eq. Charging Voltage	14.4 - 15.0 Vdc/battery 25°C (77°F)
Self-Discharge	Less than 10% after 90 days, can be stored up to 6 months at 25°C (77°F); Fully recharging is required before usage, and charged sooner if stored at higher temperature than 25°C (77°F).



Valve Regulated Lead Acid (VRLA) Battery

Maintenance-Free, Absorbent Glass Mat (AGM) Technology for Efficient Gas Recombination of up to 99%

Pure Lead Construction and Proprietary Elements

Designed for E-mobility or deep cycling applications

Built in Accordance with IEC 60254-1:2005 / IEC60254-2:2008 and UL1989 Recognized (MH14533)





EVX Series

EVX 12400 Datasheet

12V Top Terminal VRLA-AGM

Constant Current Discharge Characteristics Unit: A (25°C, 77°F)

F.V/Time	30MIN	45MIN	60MIN	90MIN	2HR	3HR	4HR	5HR	6HR	8HR	10HR	20HR
10.02V (1.67 VPC)	37.0	27.5	22.3	16.3	13.0	9.47	7.52	6.24	5.34	4.18	3.49	2.12
10.50V (1.75 VPC)	34.8	25.9	21.0	15.3	12.3	8.88	7.09	5.91	5.05	3.94	3.30	2.00
10.80V (1.80 VPC)	33.7	25.1	20.3	14.8	11.9	8.58	6.89	5.70	4.88	3.82	3.17	1.94

Constant Power Discharge Characteristics Unit: W (25°C, 77°F)

F.V/Time	30MIN	45MIN	60MIN	90MIN	2HR	3HR	4HR	5HR	6HR	8HR	10HR	20HR
10.02V (1.67 VPC)	444	330	268	196	157	113	90.1	74.6	63.1	48.4	40.0	21.6
10.50V (1.75 VPC)	417	311	252	184	147	107	84.5	69.9	59.2	45.5	37.6	20.3
10.80V (1.80 VPC)	404	300	243	178	143	103	81.5	67.4	57.1	44.0	36.4	19.6

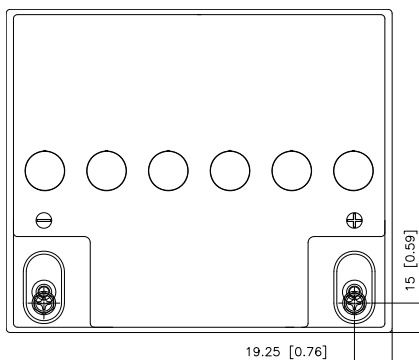

Detail A Drawing(4:1)

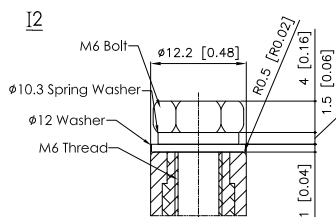

[M6 Bolt & M6 Thread & Washer & Spring Washer]

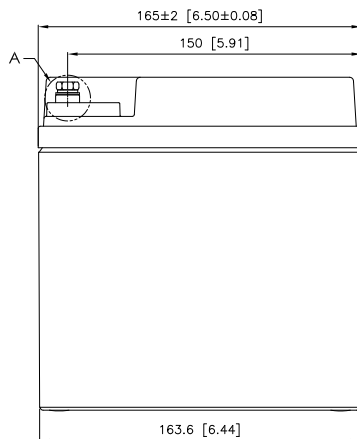
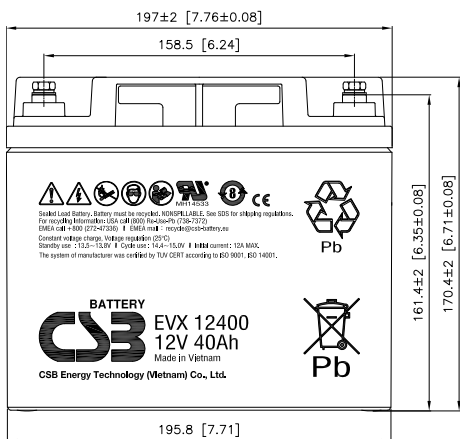

Recycle Lead Battery. Battery must be recycled. RECYCLABLE. See SDS for shipping requirements.
 For recycling information, call 800 (800) Recycle (726-2727).
 DMEG call + 800 (272-4733) • DMEG mail • recycle@csb-battery.us
 Condition of use: Energy Storage applications only (ES).
 Standby use: -15.0 ~ -15.0V @ 0.05C use: 14.4 ~ 15.0V @ 0.05C current: 12A MAX.
 The system of manufacture was certified by TÜV SÜD according to IEC 60900, IEC 14001.

BATTERY
CSB EVX 12400
12V 40Ah
 Made in Vietnam
 CSB Energy Technology (Metnam) Co., Ltd.





EVX Series

EVX 12520 Datasheet

12V Top Terminal VRLA-AGM

Specifications

Voltage (Vdc)	12
Nominal Capacity (1.75 VPC @25°C)	52 Ah @20hr-rate
Ah Capacity (8-Hr 1.75 VPC @ 25°C)	50.72
Ah Capacity (20-Hr 1.75 VPC @ 25°C)	54.4
Ah Capacity (8-Hr 1.80 VPC @ 25°C)	49.76
Max Charge Current (A)	15.60
Max Discharge Current (A)	500
Short Circuit Current (A)	1391
Internal Resistance (mΩ)	Approx. 5.2
Terminal Type	B4 terminal to accept M6 bolt
Terminal Torque	51.7±10.3 Kgf·cm / 44.9±9.0 Lbf·in / 5.1±1.0 N·m
Container Material	PP (UL 94-HB)
Weight (kg. / lb., Approx.)	17.87 / 39.39
Length (L) (mm / in)	228.0±2.5 / 8.98±0.10
Width (W) (mm / in)	138.4±1.5 / 5.45±0.06
Height (H) (mm / in)	219.3±2.5 / 8.63±0.10
Design Life	400 cycles @ 100%DOD at 25°C 1800 cycles @ 30%DOD at 25°C
Operating Temperature	Nominal: 25°C (77°F) Discharge: -15°C - 50°C (5°F-122°F) Charge/Storage: -15°C - 40°C (5°F - 104°F)
Float Charging Voltage	--
Eq. Charging Voltage	14.4 - 15.0 Vdc/battery 25°C (77°F)
Self-Discharge	Less than 10% after 90 days, can be stored up to 6 months at 25°C (77°F); Fully recharging is required before usage, and charged sooner if stored at higher temperature than 25°C (77°F).



Valve Regulated Lead Acid (VRLA) Battery

Maintenance-Free, Absorbent Glass Mat (AGM) Technology for Efficient Gas Recombination of up to 99%

Pure Lead Construction and Proprietary Elements

Designed for E-mobility or deep cycling applications

Built in Accordance with IEC 60254-1:2005 / IEC60254-2:2008 and UL1989 Recognized (MH14533)





EVX Series

EVX 12520 Datasheet

12V Top Terminal VRLA-AGM

Constant Current Discharge Characteristics Unit: A (25°C, 77°F)

F.V/Time	30MIN	45MIN	60MIN	90MIN	2HR	3HR	4HR	5HR	6HR	8HR	10HR	20HR
10.02V (1.67 VPC)	63.5	45.9	36.4	26.8	20.8	14.6	11.6	9.52	8.22	6.52	5.36	2.80
10.50V (1.75 VPC)	60.6	44.1	35.2	26.1	20.3	14.3	11.4	9.37	8.05	6.34	5.21	2.72
10.80V (1.80 VPC)	59.2	43.3	34.7	25.6	20.1	14.2	11.3	9.26	7.94	6.22	5.12	2.68

Constant Power Discharge Characteristics Unit: W (25°C, 77°F)

F.V/Time	30MIN	45MIN	60MIN	90MIN	2HR	3HR	4HR	5HR	6HR	8HR	10HR	20HR
10.02V (1.67 VPC)	656	478	382	281	219	153	123	101	87.7	70.2	58.1	33.1
10.50V (1.75 VPC)	631	463	372	273	214	151	121	99.0	85.9	68.6	56.7	31.8
10.80V (1.80 VPC)	615	455	368	269	212	150	120	98.1	84.9	67.6	55.8	31.1

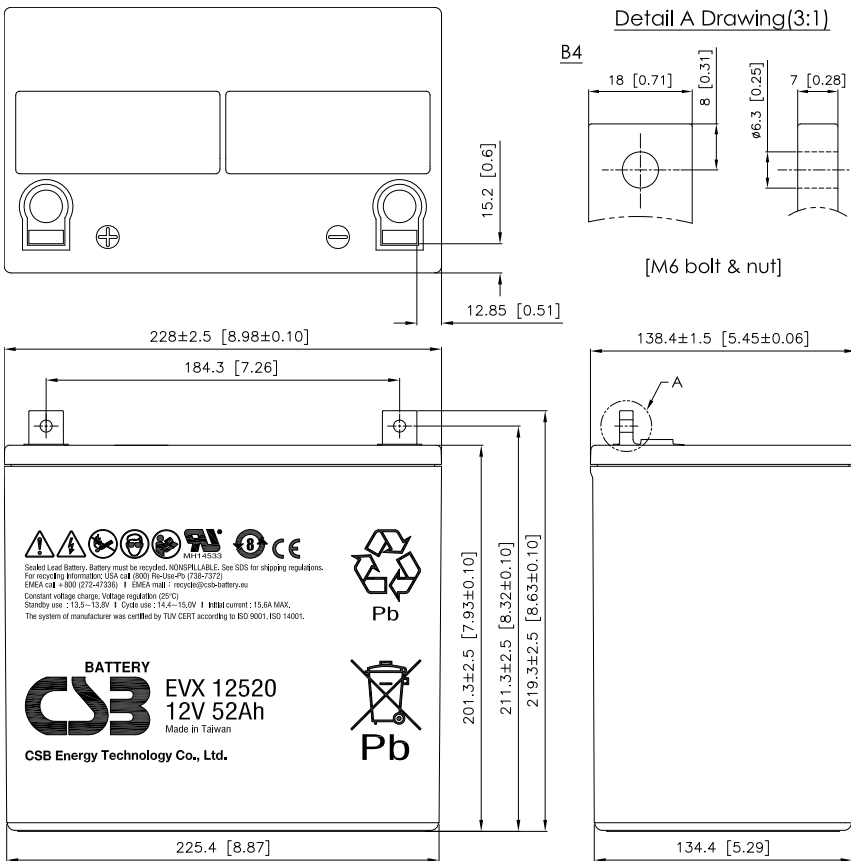



EVX Series

EVX 12750 Datasheet

12V Top Terminal VRLA-AGM

Specifications

Voltage (Vdc)	12
Nominal Capacity (1.75 VPC @25°C)	75 Ah @20hr-rate
Ah Capacity (8-Hr 1.75 VPC @ 25°C)	64.56
Ah Capacity (20-Hr 1.75 VPC @ 25°C)	75
Ah Capacity (8-Hr 1.80 VPC @ 25°C)	63.84
Max Charge Current (A)	22.50
Max Discharge Current (A)	500
Short Circuit Current (A)	1661
Internal Resistance (mΩ)	Approx. 4.7
Terminal Type	B6 terminal to accept M6 bolt
Terminal Torque	51.7±10.3 Kgf·cm / 44.9±9.0 Lbf·in / 5.10±1.0 N·m
Container Material	PP (UL 94-HB)
Weight (kg. / lb., Approx.)	25.60 / 56.38
Length (L) (mm / in)	277.0±2.5 / 10.91±0.10
Width (W) (mm / in)	168.5±2.0 / 6.63±0.08
Height (H) (mm / in)	232.5±2.5 / 9.15±0.10
Design Life	400 cycles @ 100%DOD at 25°C 1800 cycles @ 30%DOD at 25°C
Operating Temperature	Nominal: 25°C (77°F) Discharge: -15°C - 50°C (5°F-122°F) Charge/Storage: -15°C - 40°C (5°F - 104°F)
Float Charging Voltage	--
Eq. Charging Voltage	14.4 - 15.0 Vdc/battery 25°C (77°F)
Self-Discharge	Less than 10% after 90 days, can be stored up to 6 months at 25°C (77°F); Fully recharging is required before usage, and charged sooner if stored at higher temperature than 25°C (77°F).



Valve Regulated Lead Acid (VRLA) Battery

Maintenance-Free, Absorbent Glass Mat (AGM) Technology for Efficient Gas Recombination of up to 99%

Pure Lead Construction and Proprietary Elements

Designed for E-mobility or deep cycling applications

Built in Accordance with IEC 60254-1:2005 / IEC60254-2:2008 and UL1989 Recognized (MH14533)





EVX Series

EVX 12750 Datasheet

12V Top Terminal VRLA-AGM

Constant Current Discharge Characteristics Unit: A (25°C, 77°F)

F.V/Time	30MIN	45MIN	60MIN	90MIN	2HR	3HR	4HR	5HR	6HR	8HR	10HR	20HR
10.02V (1.67 VPC)	81.6	60.3	48.6	35.2	27.6	19.7	15.4	12.7	10.7	8.25	6.74	3.80
10.50V (1.75 VPC)	78.1	57.9	46.8	33.9	26.7	19.2	15.0	12.4	10.5	8.07	6.60	3.75
10.80V (1.80 VPC)	75.8	56.4	45.7	33.2	26.2	18.9	14.8	12.2	10.3	7.98	6.54	3.72

Constant Power Discharge Characteristics Unit: W (25°C, 77°F)

F.V/Time	30MIN	45MIN	60MIN	90MIN	2HR	3HR	4HR	5HR	6HR	8HR	10HR	20HR
10.02V (1.67 VPC)	906	664	532	386	309	223	175	144	122	94.3	77.0	41.2
10.50V (1.75 VPC)	863	637	513	373	299	216	170	140	119	92.3	75.7	40.7
10.80V (1.80 VPC)	839	620	500	367	293	213	168	139	118	91.3	75.0	40.6

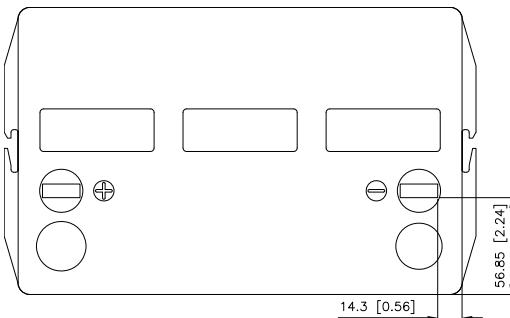

Detail A Drawing(2:1)

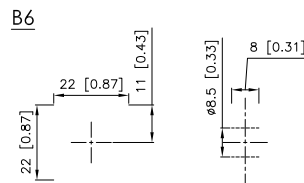

[M6 bolt & nut]

